

Dorrrough Loudness Monitor

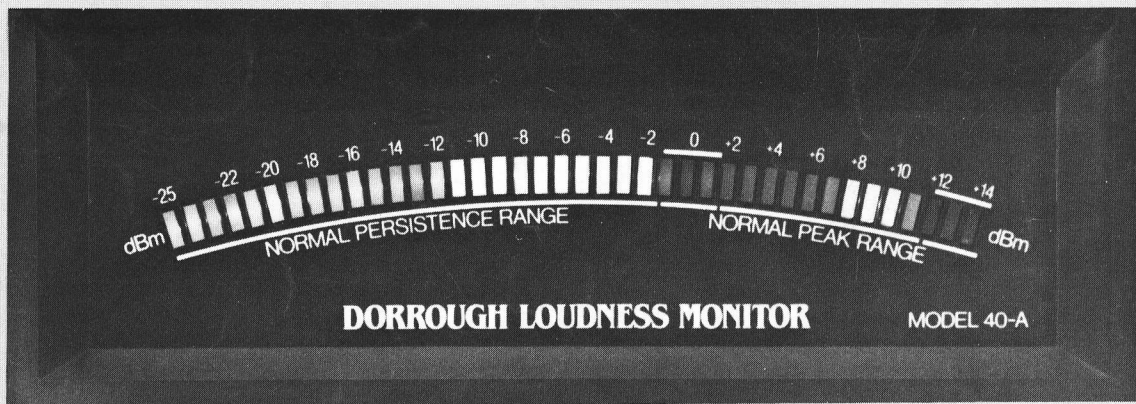

Instruction Manual Model 40-A

DORROUGH ELECTRONICS

5221 Collier Place
Woodland Hills, CA 91364
Telephone: (213) 999-1132

Dorrough Loudness Monitor

Model 40-A

Instruction Manual

Theory of Operation

The input is fed into the left and right differential amplifiers. The differential inputs are configured so that the input impedance is 20K for balanced inputs and 10K for unbalanced inputs (negative terminal is grounded for unbalanced operation).

The left input level is controlled by R-13 and the right input by R-14. The output of these two controls are fed to a summing amplifier. The feedback resistor R-18 controls the input sensitivity of the instrument. It is shipped with R-18 as 20K. The input sensitivity with this value feedback resistor is -18dBm . Changing the value of R-18 to 100K increases the sensitivity to -30dBm .

The output of the summing amplifier feeds a precision rectifier. The output of the precision rectifier feeds a split to the PEAK and PERSISTENCE circuits.

Since the desired display is to be logarithmic, the signals are fed to corresponding "linear/logarithmic" converters. The outputs of these converters feed the display drivers. The driver for the PEAK display is configured as a dot, while the driver for the PERSISTENCE display is configured as a bargraph.

Each of the 40 LEDs derives an input from both of the drivers, with the exception of the red LEDs designated as -1 , 0 , $+1$. These particular LEDs have no input from the dot driver, and therefore do not display PEAK information. This provision was made to eliminate possible confusion relative to PEAK and PERSISTENT amplitudes at this reference. With the exception of these LEDs, a steady state sinewave will illuminate a bargraph at a given amplitude, with the last displayed LED brighter than the remainder. This gives indication that the amplitude of the PERSISTENCE and the amplitude of the PEAK are equal, showing proper alignment of the instrument.

Operation

Stereophonic material, in the form of left and right inputs, is fed to the meter at the terminal strip located in the rear of the meter. Individual gain controls for the left and right inputs are also located on the rear panel.

These sources feed a 20K balanced bridging amplifier. Unbalanced 10K bridging input is accomplished by converting the minus (-) input terminal to chassis ground on the rear terminal strip.

The meter is shipped with the input controls set for $+8\text{dBm}$ as reference "0" on the meter face. Levels as low as -30dBm can be referenced to "0" by changing the value of R-18 from 20K to 100K.

If your program reference is different than that of $+8\text{dBm}$, simple adjustments or some other standard can be made by the following procedure.

Initial Set-up

Feed a 1000Hz sinewave, observing polarity, into the left input at a standard operating level (i.e., $+4$, $+8$, etc.).

Adjust the input level control on the rear panel for an indication of "0" on the PERSISTENCE scale. The peak excursion and the persistence amplitude are equal under steady state sinewave conditions.

Next, remove the signal from the left channel and feed the signal in the same polarity to the right input, making the same adjustment.

Following the adjustments for both the left and right inputs, feed the signal to both inputs simultaneously. The summing amplifier will algebraically add the two inputs for an indication of $+6$ as read on the PEAK scale. Different amplitudes and phase angles between the left and right input signals will produce different algebraic sums. This display is essential in indicating center channel buildup in some program material. Thus, this indication will aid the operator in making the proper adjustment to program operating level.

Field Alignment

All adjustments for the alignment of the LED display are located internal to the enclosure.

To gain access to these controls, the instrument is placed bottom-side-up and the six screws are removed. Once the screws are removed, place the unit right-side-up and the cabinet can be lifted from the remainder of the chassis, exposing the adjustments (see illustration "CHASSIS LAYOUT").

Procedure

1. Connect the left input to a test oscillator.
 2. Feed a sinewave tone of 1000Hz at a reference level of "0"dBm into the instrument.
 3. Adjust the left input gain control R-13 for DS-1 to be off and DS-2,3,4 to be on.
 4. Adjust the input signal to -25dBm .
 5. Adjust the low PERSISTENCE level control R-44 so that only the first LED (-25dB) at the bottom of the PERSISTENCE scale is illuminated.
 6. Adjust the low PEAK level control R-46 so that only the first LED (-25dB) at the bottom of the PERSISTENCE scale brightens. This indicates that both the PEAK and the PERSISTENCE drivers are providing current to this LED.
 7. Change the input level to $+5\text{dBm}$.
 8. Adjust the high PERSISTENCE level control R-48 so that the bargraph is illuminated up to $+5\text{dB}$.
 9. Adjust the high PEAK level control R-49 so that the $+5\text{dB}$ LED brightens. This indicates that both the PEAK and the PERSISTENCE drivers are both providing current to this LED.
 10. Increase input level to $+14\text{dBm}$. The $+14\text{dB}$ LED should indicate drive from both PEAK and PERSISTENCE drivers.
 11. Reduce input level to Reference level (i.e., $+4$, $+8$, etc.) and set the meter inputs for "0" indication on PERSISTENCE scale as described in the "INITIAL SET-UP".
 12. Alignment is now complete.
-
-

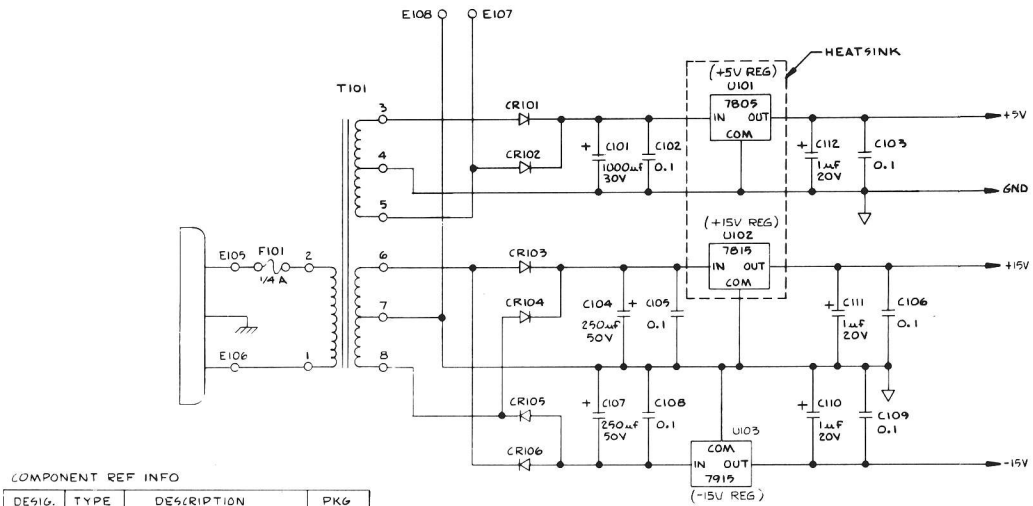

COMPONENT REF INFO

DESIG.	TYPE	DESCRIPTION	PKG
U101	7805	VOLTAGE REG 3-TERM +5V	3 (TO220)
U102	7815	" " " +15V	3 (TO220)
U103	7915	" " " -15V	3 (TO220)
T101		PWR XFMR 115V PRI	PCB MFG
J4		.025 SQ PINS 10 PIN HEADER	10 PIN DUAL .10

Power Supply

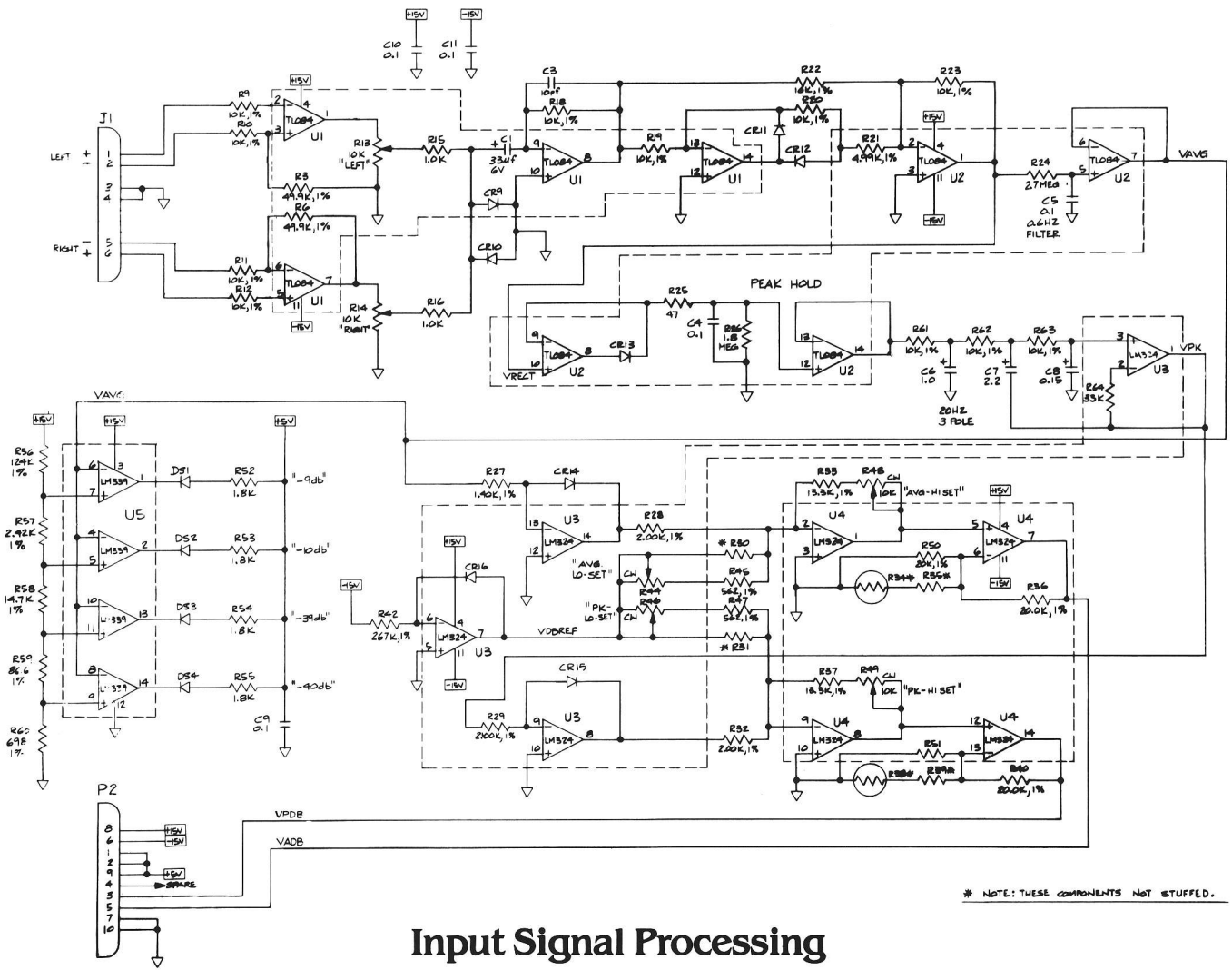

Input Signal Processing

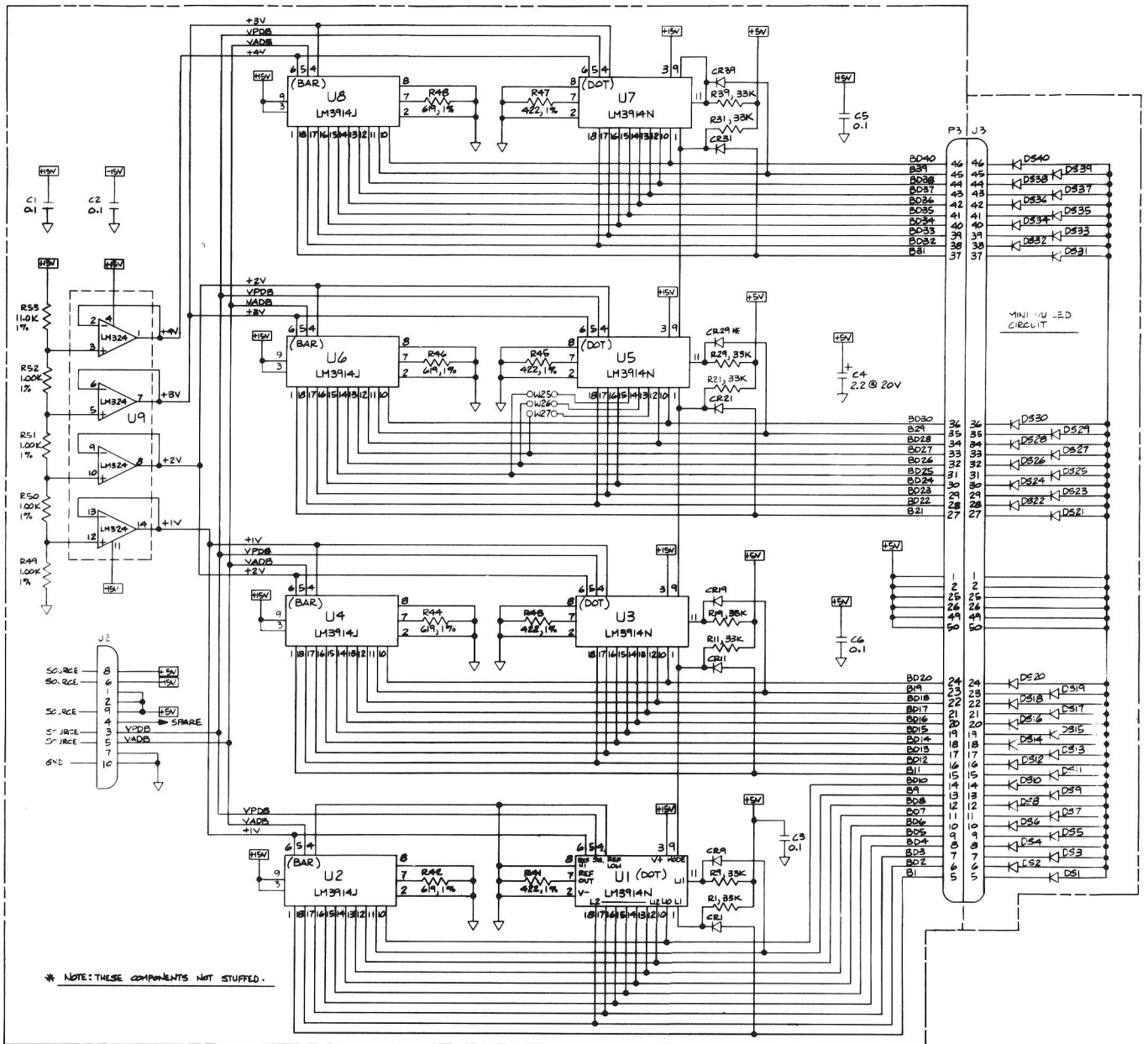

Bar and Peak Driver Circuits

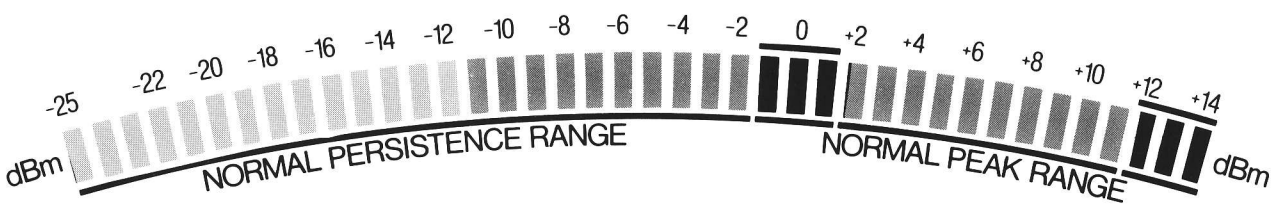

Meter Scale

MODEL 40-A

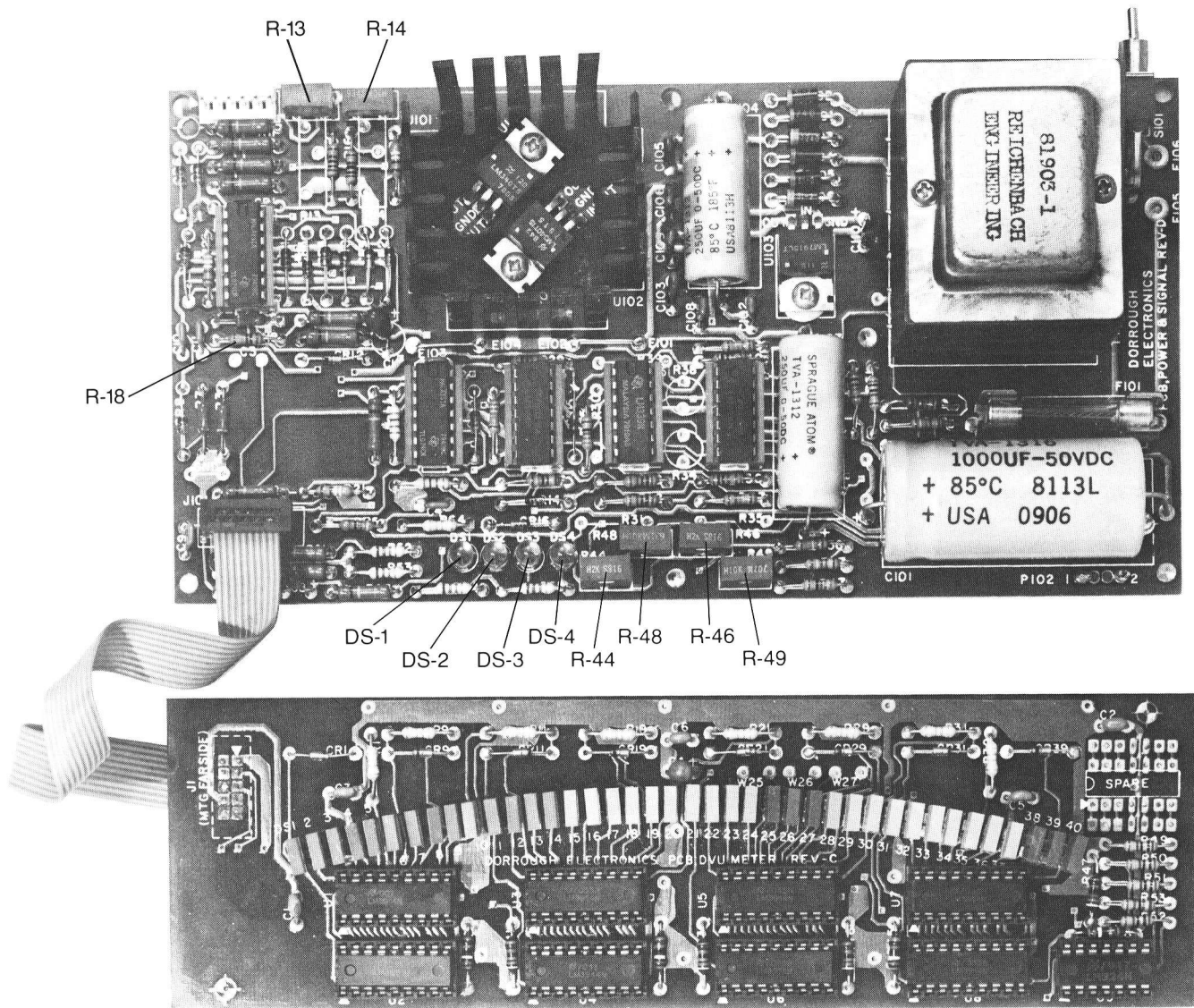

Chassis Layout

DORROUGH ELECTRONICS

5221 Collier Place
Woodland Hills, CA 91364
Telephone: (213) 999-1132
